

## STAINLESS STEEL THREADED BALL CHECK VALVE PN16

Stainless steel ball check valve for waste water, viscous and dense fluids.  
Stainless steel body EN 1.4401 with stainless steel bolting.  
Bolted bonnet for easy maintenance.



**Size :** DN1"1/4 to DN2"  
**Connection :** Female BSP  
**Min Temperature :** +0°C  
**Max Temperature :** +150°C  
**Max Pressure :** 16 Bars  
**Specifications :** Ball type  
Horizontal or vertical with ascending fluid position  
Bolted bonnet

**Materials :** Stainless steel EN 1.4401

**STAINLESS STEEL THREADED BALL CHECK VALVE PN16**

**SPECIFICATIONS :**

- Ball type
- Vertical position with ascendant fluid or horizontal position (respect the flow direction indicated by the arrow )
- Female / female threaded
- Bolted bonnet for easy maintenance
- EN 1.4401 body
- FPM gasket
- Check valve tested individually at 3 bars of compressed air
- Back pressure for tightness : 0.4 bar minimum in horizontal position

**USE :**

- Waste water, viscous and dense fluids
- Min Temperature Ts : + 0°C
- Max Temperature Ts :+ 150°C
- Max Pressure Ps : 16 bars

**HEAD LOSS GRAPH :**

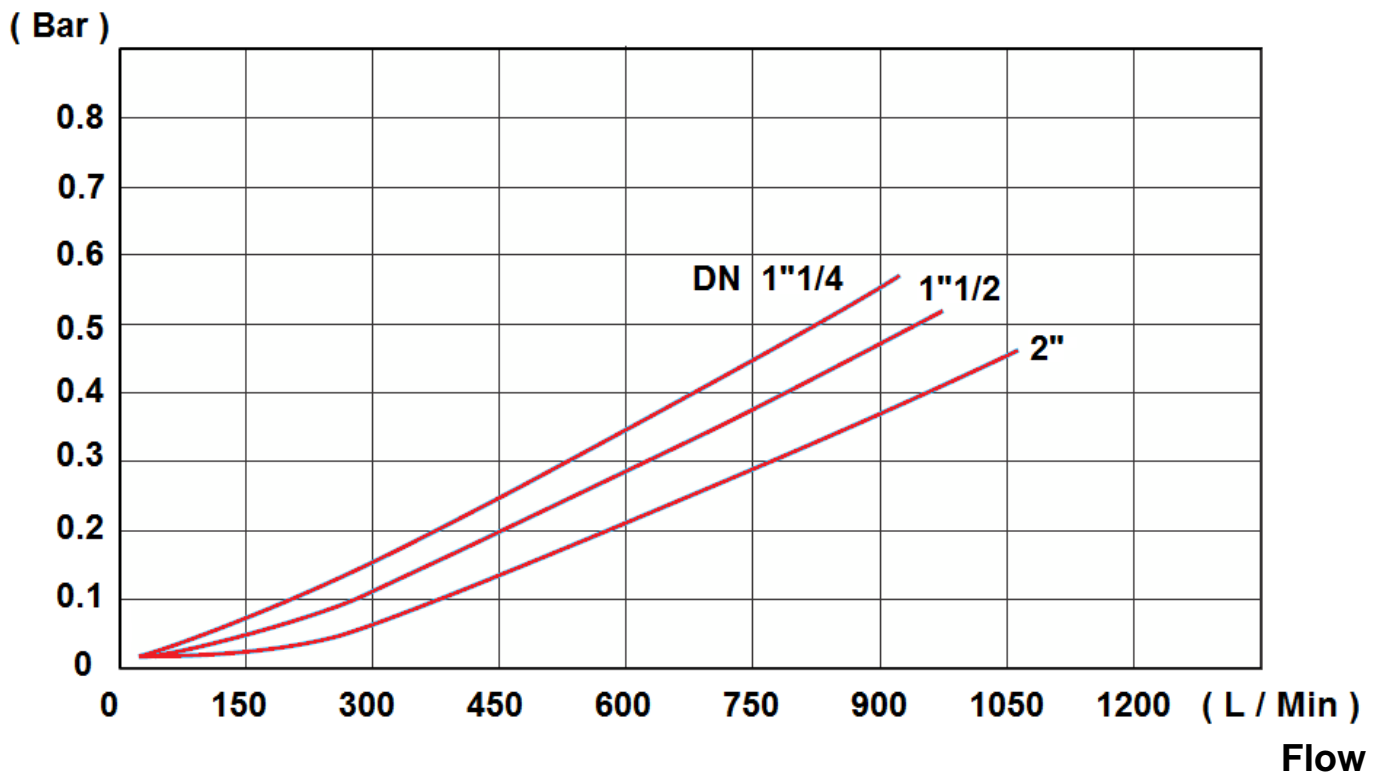

**RANGE :**

- Female / female threaded cylindrical BSP **Ref. 339** from DN1 1/4 to 2"

**STAINLESS STEEL THREADED BALL CHECK VALVE PN16**

**MATERIALS :**

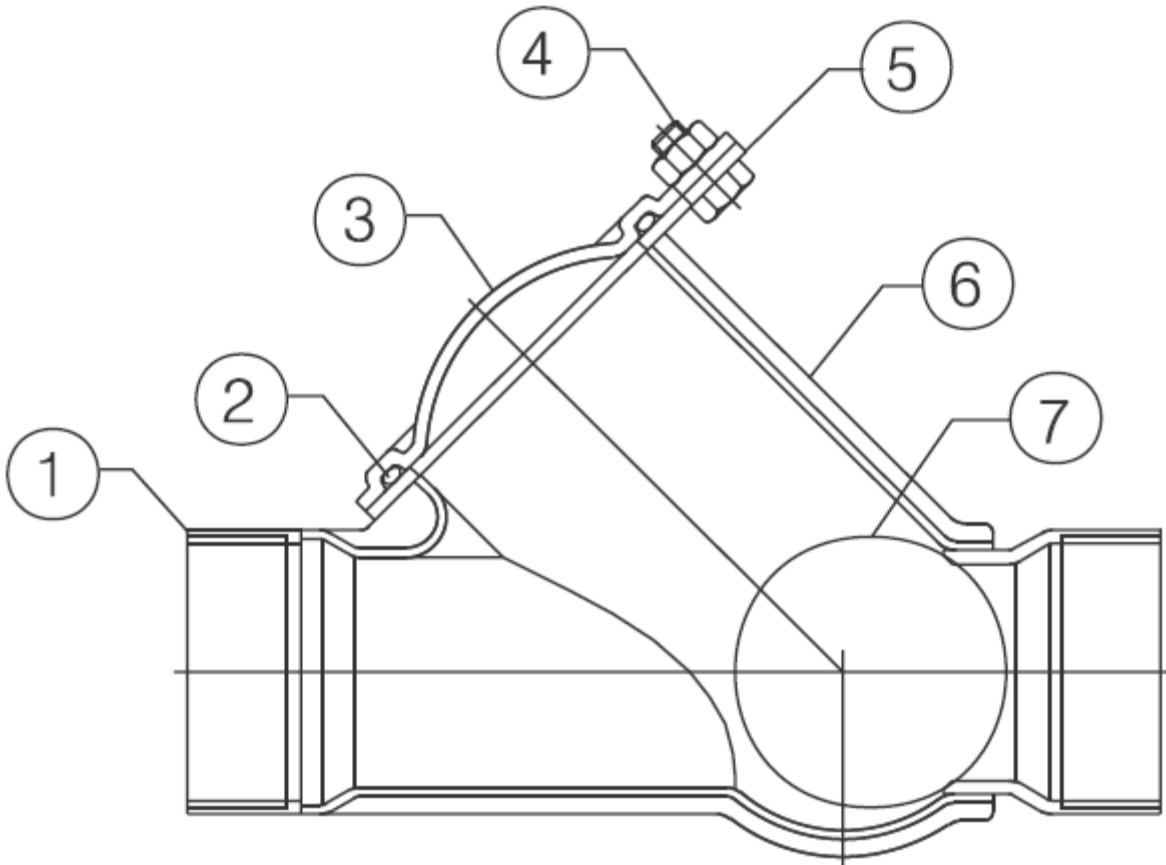

Item	Designation	Materials
1	Nipple	EN 1.4401
2	Bonnet gasket	FPM
3	Bonnet	EN 1.4401
4	Bolting	
5	Collar	
6	Body	
7	Ball	Aluminium FPM coated

**STAINLESS STEEL THREADED BALL CHECK VALVE PN16**

**SIZE ( in mm ) :**

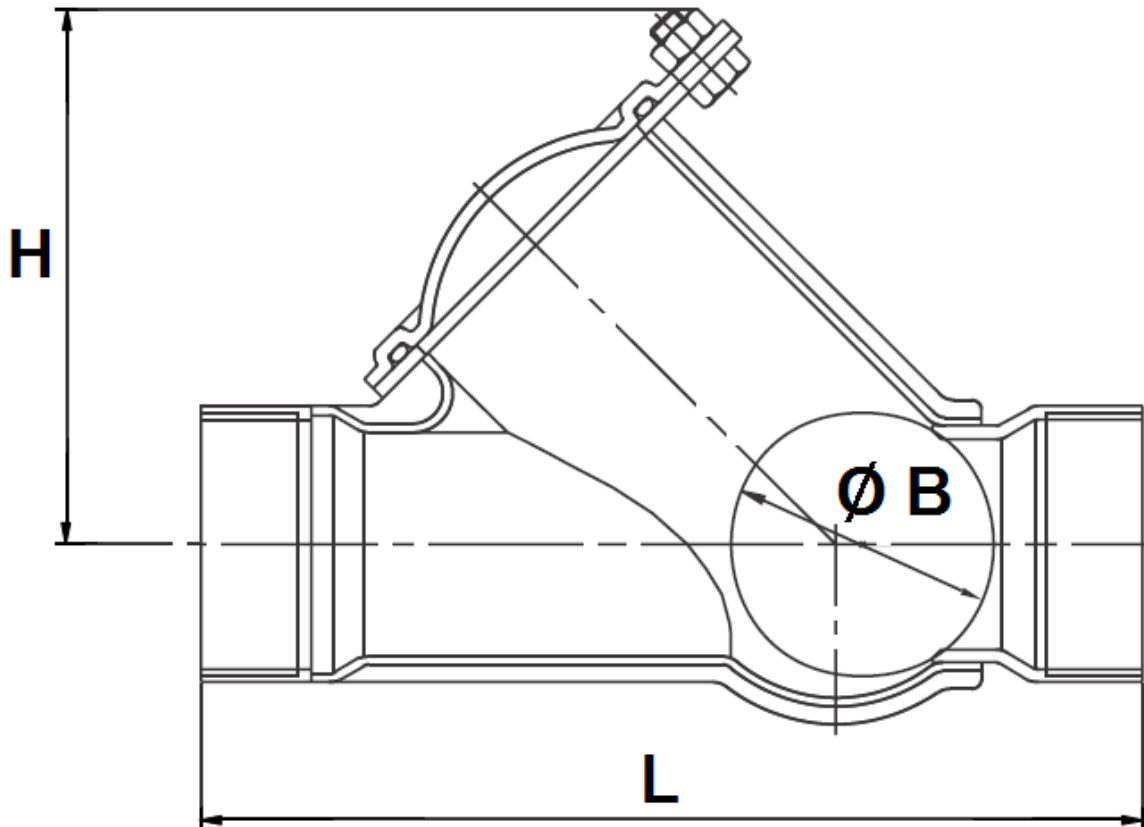

DN	1" 1/4	1" 1/2	2"
L	175	190	210
H	99	99	112
Ø B	50	50	60
Weight (in Kg)	1.1	1.18	1.61

**STAINLESS STEEL THREADED BALL CHECK VALVE PN16**

**STANDARDS :**

- Manufacturer certified ISO 9001: 2015
- DIRECTIVE 2014/68/EU : Products excluded from directive ( Article 4, § 3 )
- Cylindrical female BSP threaded according to ISO 228-1

**INSTALLATION POSITIONS :**

**Vertical position ( Ascendant fluid )**

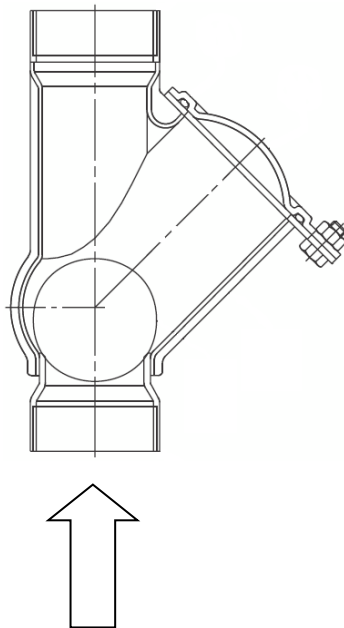

**Horizontal position**

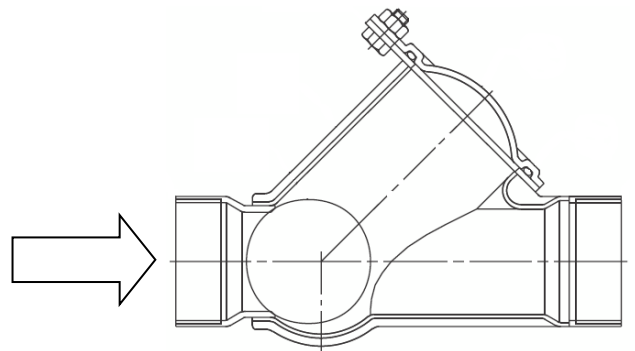

**ADVICE :** Our opinion and our advice are not guaranteed and SFERACO shall not be liable for the consequences of damages. The customer must check the right choice of the products with the real service conditions.

**STAINLESS STEEL THREADED BALL CHECK VALVE PN16****INSTALLATION INSTRUCTIONS****GENERAL GUIDELINES :**

- Ensure that the check valves to be used are appropriate for the conditions of the installation (type of fluid, pressure and temperature).
- Be sure to have enough valves to be able to isolate the sections of piping as well as the appropriate equipment for maintenance and repair.
- Ensure that the valves to be installed are of correct strength to be able to support the capacity of their usage.

**INSTALLATION INSTRUCTIONS :**

- **Before installing the check valves, clean and remove any objects from the pipes** (in particular bits of sealing and metal) which could obstruct and block the valves.
- **Ensure that both connecting pipes either side of the check valve (upstream and downstream) are aligned (if they're not, the valves may not work correctly).**
- **Make sure that the two sections of the pipe (upstream and downstream) match, the check valve unit will not absorb any gaps. Any distortions in the pipes may affect the tightness of the connection, the working of the check valve and can even cause a rupture.** To be sure, place the kit in position to ensure the assembling will work.
- Before starting the fitting, ensure that the threads and tapping are clean.
- **If sections of piping do not have their final support in place, they should be temporarily fixed. This is to avoid unnecessary strain on the check valve.**
- The theoretical lengths given by ISO/R7 for the tapping are typically longer than required, the length of the thread should be limited, and **check that the end of the tube does not press right up to the head of the thread.**
- When screwing the check valve, ensure that you only rotate on screwed side by the 6 ended side. Use an open ended spanner or an adjustable spanner and not a monkey wrench.
- **Never use a vice to tighten the fixings of the check valve.**
- Do not over tighten the check valve. Do not block with any extensions as it may cause a rupture or weakening of the casing.
- If there is a direction changing or if there's another material, it's better to take away the check valve so that it is outside the turbulence area ( **between 3 and 5 times the ND before and after** ).
- After a pump please refer to FD CEN/TR 13932 to install the check valve.