

## INSTALLATION OPERATING MANUAL NO POLLUTION CHECK VALVE EA577

No pollution check valve NF EA 577 ACS to protect drinking water networks.  
Ductile iron EN GJS-450-10 body and EPDM gasket.  
Weak head loss.  
Controlable.



**Size :** DN40 à DN150  
**Connection :** Flanges RF PN10/16  
**Min Temperature :** -10°C  
**Max Temperature :** +60°C (+90°C for return circuit)  
**Max Pressure :** 16 Bars  
**Specifications :** Check valve EA577  
Controlable  
With removable bonnet  
EPDM gasket  
Weak head loss

**Materials :** Ductile iron body EN GJS-450-10

**INSTALLATION OPERATING MANUAL NO POLLUTION CHECK VALVE EA577**

**SPECIFICATIONS :**

- Respect the flow direction indicated by the arrow
- Upstream and downstream pressure tapping ( Valves DN 1/2" BSP )
- Controllable
- Low head loss
- Removable bonnet
- Epoxy coated by cataphoresis + powder

**USE:**

- Water distribution
- Min Temperature Ts : + 10°C
- Max Temperature Ts :+ 60°C ( +90°C max for return circuit )
- Max Pressure Ps : 16 bars

**HEAD LOSS GRAPH :**

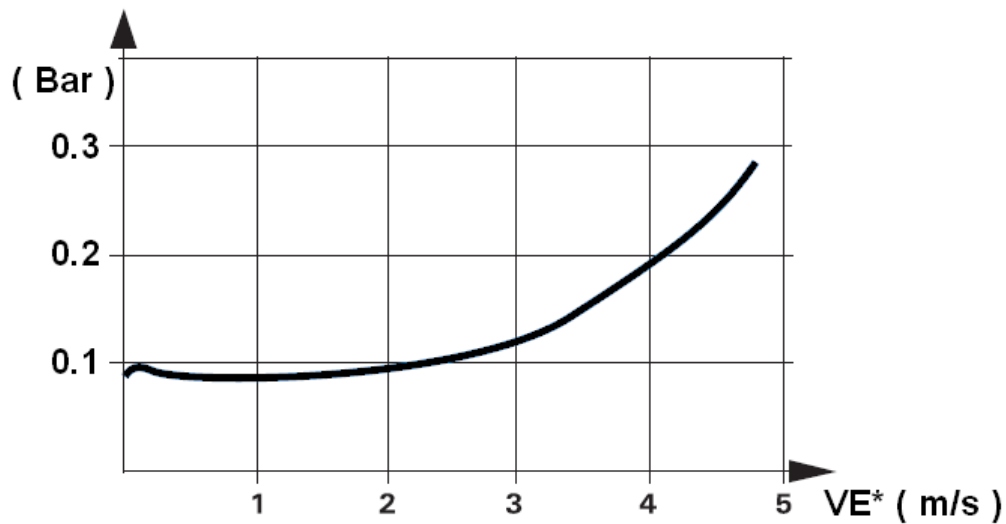

VE\* : Equivalent speed (average speed in entry section )

**FLOW :**

DN	40/50	60/65	80	100	150
Flow ( l/s )	5.5	11.6	17.5	27.5	62

Flow for a head loss of 0.15 bar, determined by NF P 43-017.

**INSTALLATION OPERATING MANUAL NO POLLUTION CHECK VALVE EA577**

**WORKING :**

The disc of the check mechanism is pushed by the spring and so that create a mini pressure differential above 10 water-volume meter, in accordance with NF 43-017 standard. In operating, the downstream pressure is lower than the upstream one, ever if there is no flow : that provides a good tightness. If for some reasons, a backpressure in the downstream line or a depression on the upstream line occur, the difference pressure between upstream and downstream would decrease; the check mechanism would close and ensure tightness before reversing stream. The anticipation at the closing define NOREPOL as an Anti-pollution device.

**RANGE :**

- PN10/16 flanges from DN 40 to DN150 Ref.346

**MATERIALS :**

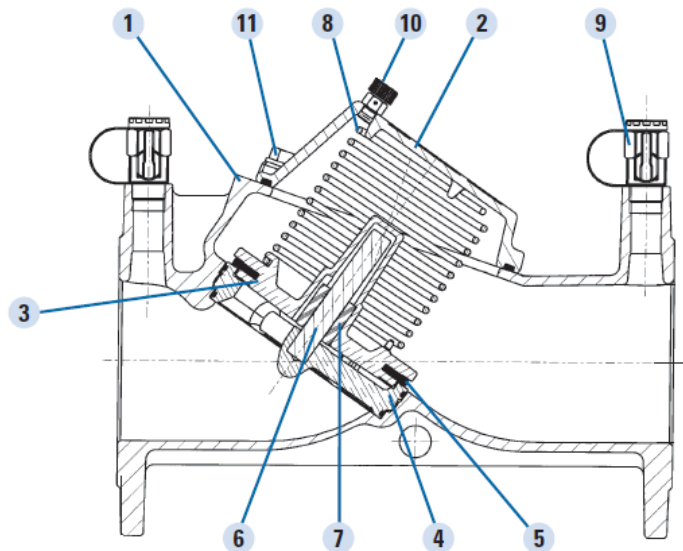

Item	Designation	Materials
1	Body	Ductile iron EN-GJS-450-10
2	Bonnet	Ductile iron EN-GJS-450-10
3	Disc support	Bronze
4	Disc seat	Bronze
5	Disc	EPDM
6	Stem	Stainless steel or bronze according to DN
7	Scale inhibitor	PETP
8	Spring	AISI 302
9	Pressure tapping valve	PTFE, master alloy, plastic
10	Drainer	Nickeled master alloy + POM
11	Screw and washer	A2

## INSTALLATION OPERATING MANUAL NO POLLUTION CHECK VALVE EA577

### Backflow

Drinking water supplied by the public network may suffer from hazardous pollution caused mainly by contaminated fluids from plumbing systems flowing back directly into the public network.

This phenomenon, called "backflow", occurs when:

- the pressure in the public network is lower than that in the plumbing circuit receiving the supply (back siphoning). This situation may occur when a pipe is broken in the public system or when other consumer demand on the public network is very heavy.
- the pressure in the plumbing circuit receiving the supply rises (back pressure) due, for example, to water being pumped from a well.



### Risk assessment

Given the potential dangers of the phenomenon and the requirements of current regulations, the risk of pollution caused by backflow must be assessed on the basis of the type of system and the characteristics of the fluid that flows inside it. A suitable backflow prevention device must be selected on the basis of the assessment performed by the system designer and the public network supplier. The device must be located along the supply line at the points at risk of backflow which would be hazardous to human health.

The protection can be provided by fitting a check valve at critical points in the circuit, at the inlet from the public network or in the internal plumbing system. This will prevent the backflow of polluted water in all systems for which direct connection to the public or an internal network is considered hazardous.

### Application of the EA type anti-pollution check valve – with reference to European standard EN 1717 and EN 13959

Proper use of the EA type anti-pollution check valve is regulated by the new European standards relating to the prevention of pollution caused by backflow.

The reference standard is EN 1717: 2000 "Protection against pollution of drinking water in hydraulic systems and general requirements for the devices used to prevent pollution caused by backflow". In this standard, the water in the systems is classified according to the level of risk it represents for human health.

#### Category 1:

Water suitable for human consumption supplied by the water supplier.

#### Category 2:

Fluid that does not represent a health hazard, as in number 1, the quality of which has been compromised due to changes in temperature, taste, smell or appearance.

#### Category 3:

Fluid that represents a slight health risk due to the presence of one or more harmful substances.

#### Category 4:

Fluid that represents a health hazard due to the presence of one or more "toxic" or "highly toxic" substances, or one or more radioactive, mutagenic or carcinogenic substances.

#### Category 5:

Fluid that represents a severe health hazard due to the presence of microbiological or viral elements.

According to this classification, suitable backflow prevention devices must be fitted in water distribution plant systems.

**EA type anti-pollution check valves can be used to offer protection against the risk of water contamination up to category 2.**

**For category 3 water, it is necessary to use a CA type backflow preventer.**

The table below, called the "Protection matrix", associates the various types of system with the relative fluid categories and has been created based on the indications provided in the European regulations.

The new European standard EN 13959 – "Anti-pollution check valves from DN 6 to DN 250. Family E, type A, B, C and D." defines the functional, dimensional and mechanical requirements of anti-pollution check valves.

Protection matrix		
Type of system	Cat. of fluid	
	2	3
<b>General</b>		
Hot and cold water mixing devices in domestic water systems	*	
Water cooling devices for air conditioning units, without additives	*	
Sterilisers for packaged or disinfected materials		*
Water in primary domestic heating system circuits, without additives		*
<b>Domestic, residential or commercial gardens</b>		
Hand-held fertiliser sprayers for use in domestic gardens		*
Watering systems, without fertilisers or insecticides, with sprinkler fixed to the ground at a depth of not more than 150 mm		*
<b>Water softeners</b>		
Domestic water softeners regenerated with common salt	*	
Commercial water softeners (only regenerated with common salt)		*
<b>Commercial applications</b>		
Automatic dispensers <b>with</b> injection of ingredients or CO <sub>2</sub>		*
Automatic dispensers <b>without</b> injection of ingredients or CO <sub>2</sub>	*	
Machines to wash out drink distribution pipes in restaurants		*
Hairdresser rinsing systems	*	
<b>Medicine</b>		
X-ray machine cooling systems	*	
<b>Food applications</b>		
Ice-making machines	*	
Large kitchen machines with automatic filling system	*	
<b>Household applications</b>		
Water in sinks, baths and showers	*	
Domestic dishwashers and washing machines		*
Flexible pipes with controlled flow spray nozzles or stop cock		*
Domestic dialysis machines		*

**INSTALLATION OPERATING MANUAL NO POLLUTION CHECK VALVE EA577**

**INSTALLATION :**

The no pollution check valve EA 577 Norepol is a safety device and it's necessary to install a valve before. It's necessary to install a valve and a strainer with drain before so that maintenance operations would be easier. It must be fitted in an accessible place. The installation position is horizontal or vertical. Before the installation of the Norepol check valve, please clean the pipe.

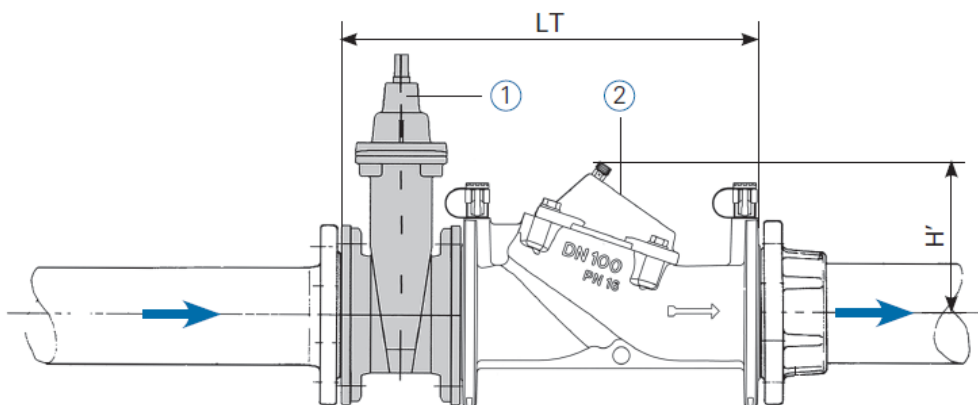

DN	Lt mm	H' mm
50	383	290
65	463	320
80	493	350
100	543	400
150	693	564
200	833	600
250	983	500

H' : Minimum high to remove the bonnet

1. Gate valve
2. Norepol EA577 Ref.346 check valve

**INSTALLATION OPERATING MANUAL NO POLLUTION CHECK VALVE EA577**

**GENERAL GUIDELINES :**

- Ensure that the check valves to be used are appropriate for the conditions of the installation (type of fluid, pressure and temperature).
- Be sure to have enough valves to be able to isolate the sections of piping as well as the appropriate equipment for maintenance and repair.
- Ensure that the valves to be installed are of correct strength to be able to support the capacity of their usage.

**INSTALLATION INSTRUCTIONS :**

- **Before installing the check valves, clean and remove any objects from the pipes** (in particular bits of sealing and metal) which could obstruct and block the valves.
- Flanges faces must be clean and without damaged
- **Ensure that both connecting pipes either side of the check valve (upstream and downstream) are aligned (if they're not, the valves may not work correctly).**
- **Make sure that the two sections of the pipe (upstream and downstream) match, the check valve unit will not absorb any gaps. Any distortions in the pipes may affect the tightness of the connection, the working of the check valve and can even cause a rupture.** To be sure, place the kit in position to ensure the assembling will work.
- **If sections of piping do not have their final support in place, they should be temporarily fixed. This is to avoid unnecessary strain on the check valve.**
- Respect the flow direction indicated by the arrow
- Ensure there is enough space after the check valve so that the disc could be opened in total opening position
- Bolting should be tighten in cross
- If there is a direction changing or if there's another material, it's better to take away the check valve so that it is outside the turbulence area ( **between 3 and 5 times the ND before and after** ).