

RUBBER EXPANSION JOINT TEGUFLEX® PU WHITE FOOD NBR

Rubber expansion joint Teguflex white food NBR with swiveling flanges to absorb vibrations and noises food and beverages networks, included fats and oils.

Not advisable for aromatic solvent (50%), ozone and UV.

Body in white food NBR and carbon steel dichromate zinc plated or AISI 316 flanges.

For linear and angular compansion.

130 mm long for all DN.

Rubber expansion joint according to CE 1935/2004



Size : DN25 to DN300
Connection : Flanges PN10/16
Min Temperature : -25°C
Max Temperature : +90°C
Max Pressure : 16 Bars (10 bars at 90°C)
Specifications : Absorb vibrations and noise
Linear and angular compansion
NBR Tube

Materials : Dichromate zinc plated steel flanges or AISI 316

RUBBER EXPANSION JOINT TEGUFLEX® PU WHITE FOOD NBR

SPECIFICATIONS :

- Absorb vibration, noises and expansion
- Linear and angular compansion
- Inner tube food NBR (FDA)
- 130 mm length
- Dichromate zinc plated steel or AISI 316 swiveling flanges PN10/16 up to DN150, PN10 over
- On request, PN6, PN16 and Class 150 PN20 flanges
- AISI 316 Ti vacuum ring on request (Ref.9815050 to 9815300)
- Inner liner PTFE on request (movements allowed by the expansion joints are then reduced by 50 % and pressure max is 6 bars)
- Bursting pressure >50 bar at 20°C
- Test pressure 25 bar at 20°C

USE :

- Food and beverages, included fats and oils
- Not advisable for aromatic solvent (50%), ozone and UV
- Min and max temperature Ts : - 25°C to + 90°C
- Max pressure Ps : 16 bars at 70°C and 10 bars at 90°C (6 bars with PTFE lining)

PRESSURE / TEMPERATURE GRAPH (STEAM EXCLUDED):

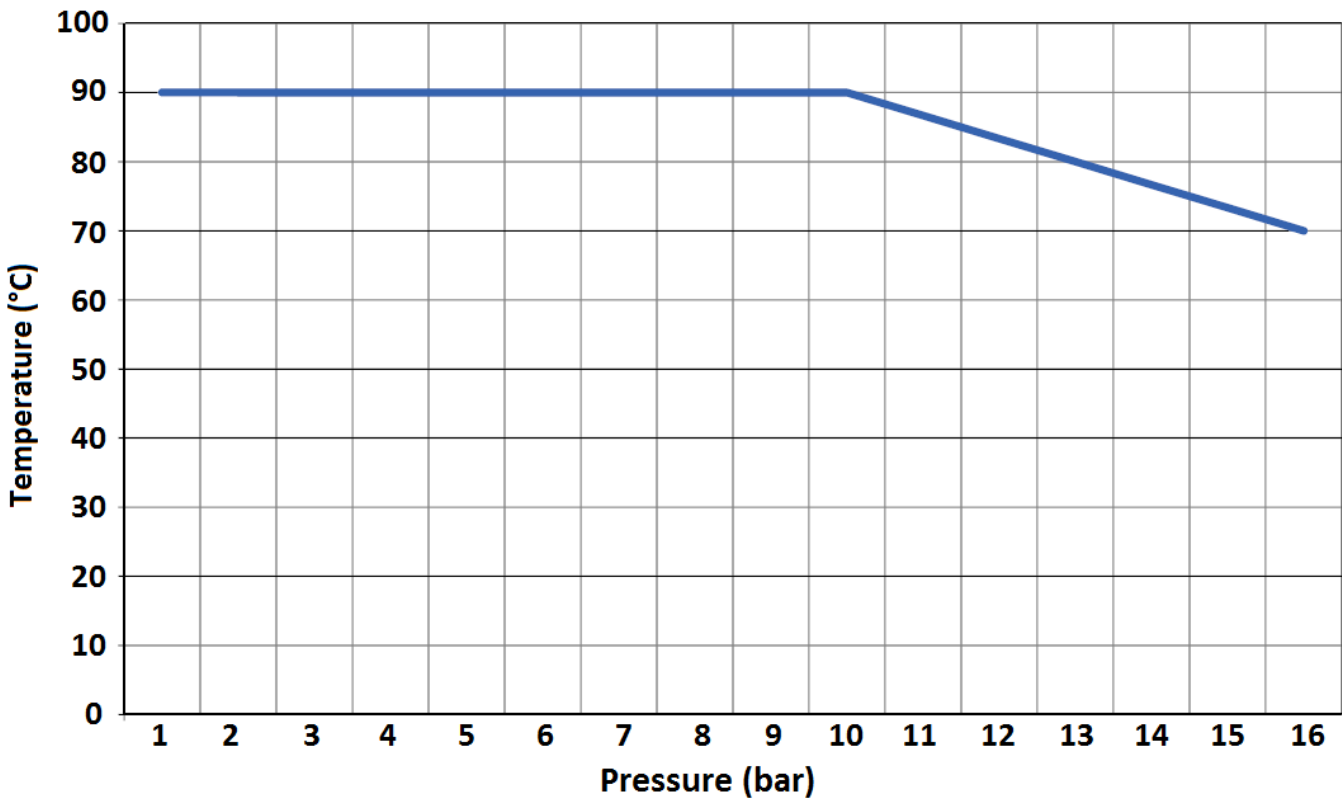

MAXIMUM VACUUM :

DN	25/32	40	50	65	80	100	125	150	200	250	300
Vacuum (bar)	-0.8	-0.8	-0.7	-0.6	-0.5	-0.5	-0.4	-0.3	-0.3	-0.2	-0.2

RUBBER EXPANSION JOINT TEGUFLEX® PU WHITE FOOD NBR

RANGE :

- Food NBR (FDA) expansion joint with AISI 316 or dichromate zinc plated steel flanges PN10/16 from DN 25 to DN 150, PN10 over Ref. 1565
- **On Request :**

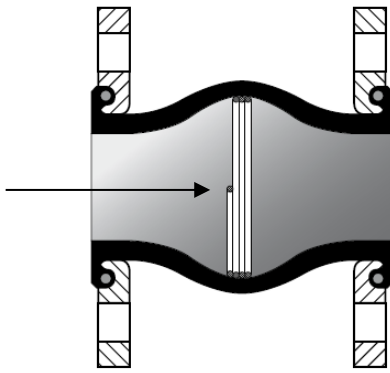

- AISI 316 Ti vacuum ring (vacuum up to -1 bar) Ref.9815050 to 9815300

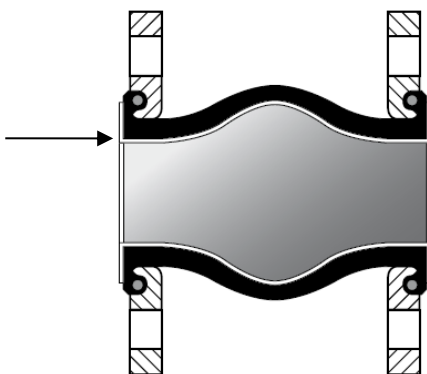

- Inner liner PTFE (movements allowed by the expansion joints are then reduced by 50 % and pressure max is 6 bars)

RUBBER EXPANSION JOINT TEGUFLEX® PU WHITE FOOD NBR

MATERIALS :

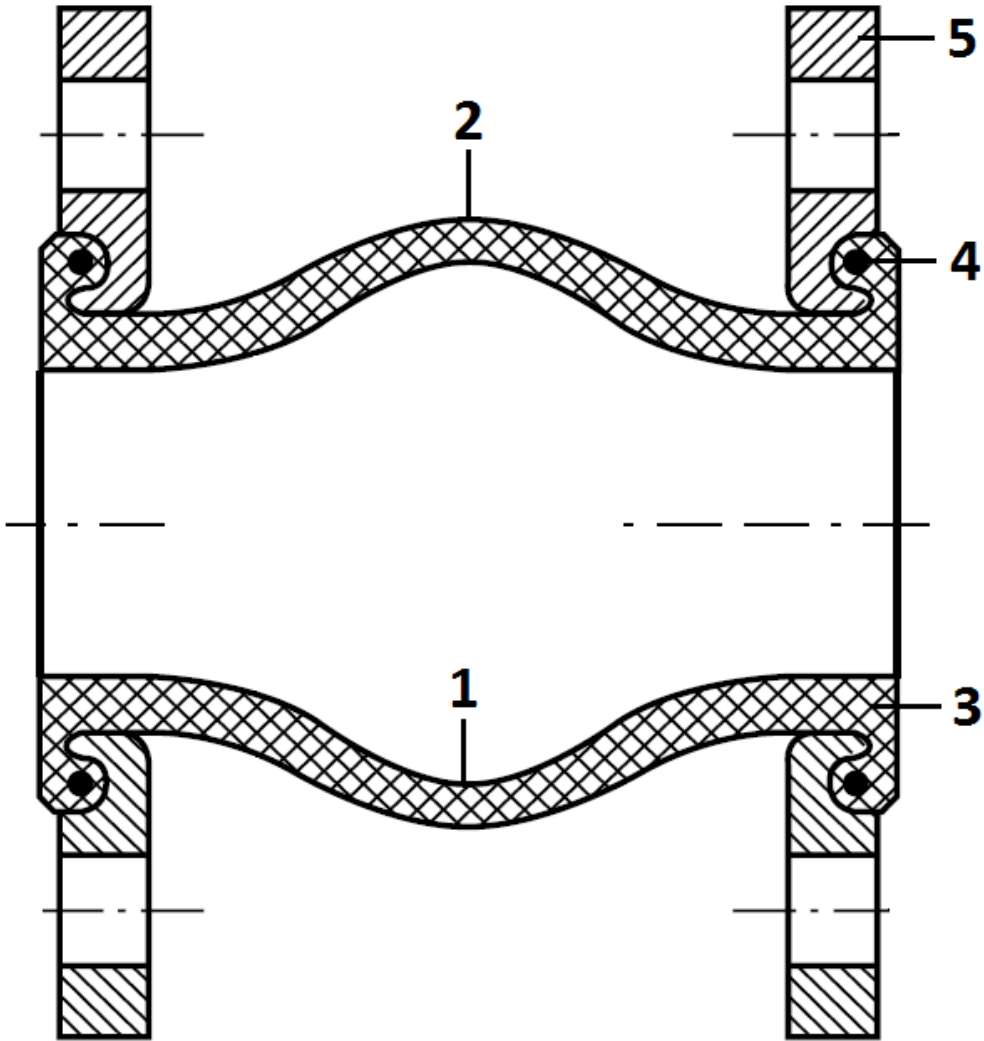

Item	Designation	Materials
1	Inner tube	Food NBR FDA
2	Outer cover	Epichlorhydrin (ECO)
3	Reinforcement	Synthetic textile
4	Brace	Carbon steel
5	Swiveling flanges	Dichromate zinc plated steel or AISI 316

RUBBER EXPANSION JOINT TEGUFLEX® PU WHITE FOOD NBR

SIZE (in mm) :

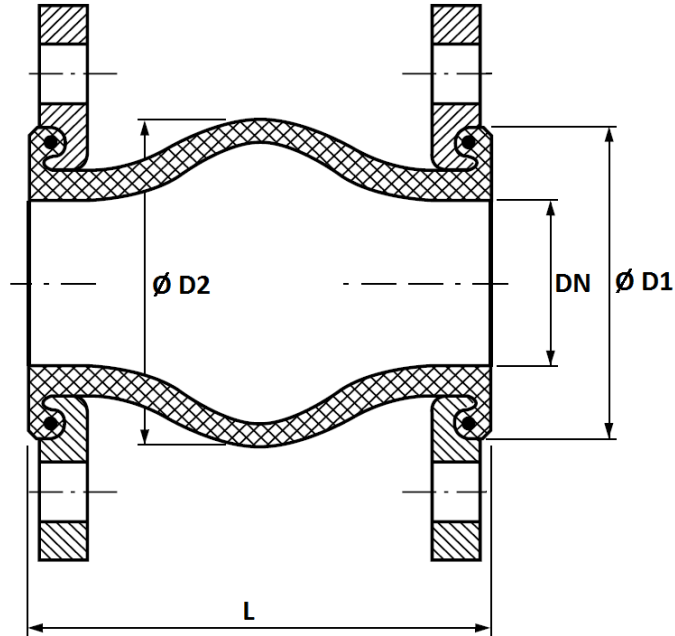

DN	25/32	40	50	65	80	100	125	150	200	250	300
L	130	130	130	130	130	130	130	130	130	130	130
Ø D1	72	80	90	105	120	140	165	190	240	290	340
Ø D2	77	85	95	110	125	145	170	195	245	295	345
Weight (Kg)	2.8	3.3	3.7	4.8	5.3	6.2	8.2	11.2	16.8	21.6	30.1
Ref.	1565032	1565040	1565050	1565065	1565080	1565100	1565125	1565150	1565200	1565250	1565300

STANDARD FLANGES PN10 (PN10/16 UP TO DN150) SIZE (in mm) :

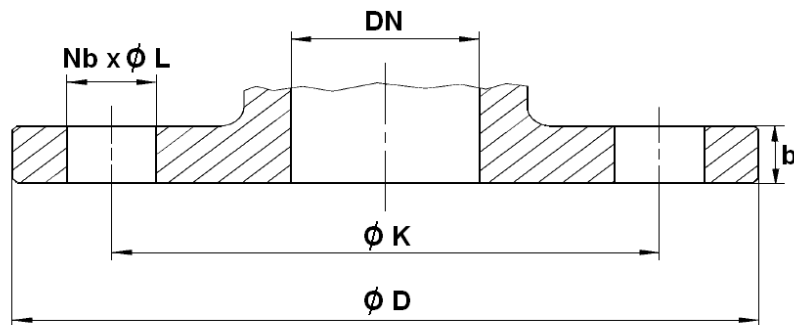

DN	25	32	40	50	65	80	100	125	150	200	250	300
Ø D	115	140	150	165	185	200	220	250	285	340	395	445
Ø K	85	100	110	125	145	160	180	210	240	295	350	400
Nb x Ø L	4x14	4 x 18	4 x 18	4 x 18	4 x 18	8 x 18	8 x 18	8 x 18	8 x 22	8 x 22	12 x 22	12 x 22
b	13.8	13.8	14	14.1	14.4	14.8	15.2	16	17.8	20.2	22.6	26.5

RUBBER EXPANSION JOINT TEGUFLEX® PU WHITE FOOD NBR

SIZE OF FLANGES ON REQUEST :

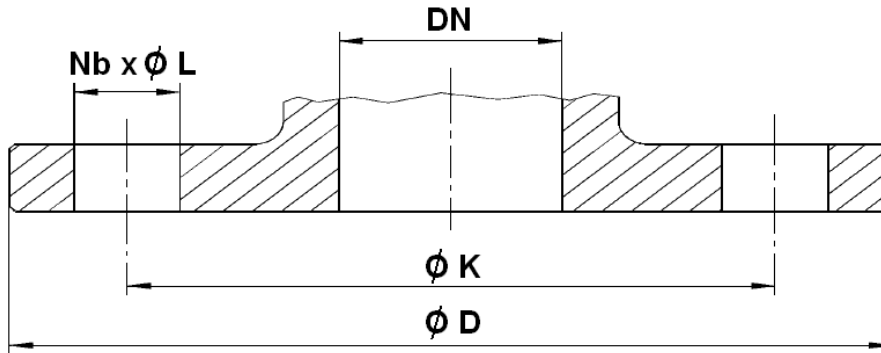

PN6 FLANGES (in mm) :

DN	25	32	40	50	65	80	100	125	150	200	250	300
Ø D	100	120	130	140	160	190	210	240	265	320	375	440
Ø K	75	90	100	110	130	150	170	200	225	280	335	395
Nb x Ø L	4 x 11	4 x 14	4 x 14	4 x 14	4 x 14	4 x 18	4 x 18	8 x 18	8 x 18	8 x 18	12 x 18	12 x 22

PN16 FLANGES (in mm) :

DN	200	250	300
Ø D	340	405	460
Ø K	295	355	410
Nb x Ø L	12 x 22	12 x 26	12 x 26

Class 150 PN20 FLANGES (in mm) :

DN (mm)	25	32	40	50	65	80	100	125	150	200	250	300
NPS (")	1"	1"1/4	1"1/2	2"	2"1/2	3"	4"	5"	6"	8"	10"	12"
Ø D	108	117	127	152	178	190	229	254	279	343	406	483
Ø K	79.4	88.9	98.4	120.6	139.7	152.4	190.5	215.9	241.3	298.4	361.9	431.8
Nb x Ø L	4 x 15.9	4 x 15.9	4 x 15.9	4 x 19	4 x 19	4 x 19	8 x 19	8 x 22.2	8 x 22.2	8 x 22.2	12 x 25.4	

RUBBER EXPANSION JOINT TEGUFLEX® PU WHITE FOOD NBR

MOVEMENTS (in mm) :

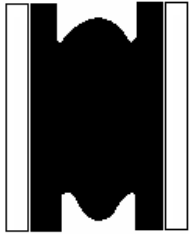

Compansion

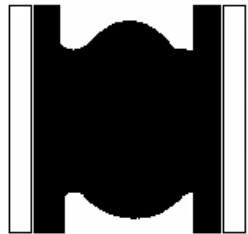

Expansion

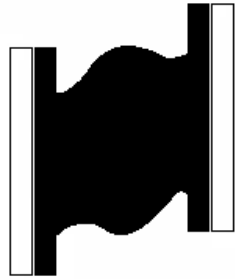

Lateral

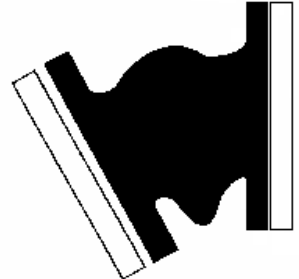

Angular

DN	25-50	65	80	100	125	150	200	250	300
Compansion	30	30	30	30	30	30	30	30	30
Expansion	20	20	20	20	20	20	20	20	20
Lateral	20	20	20	20	20	20	20	20	20
Angular	35°	30°	30°	25°	25°	15°	15°	10°	10°

**Maximum movements can't be applied simultaneously.
For example, with an expansion of 15mm, the maximum lateral movement will be 8 mm :**

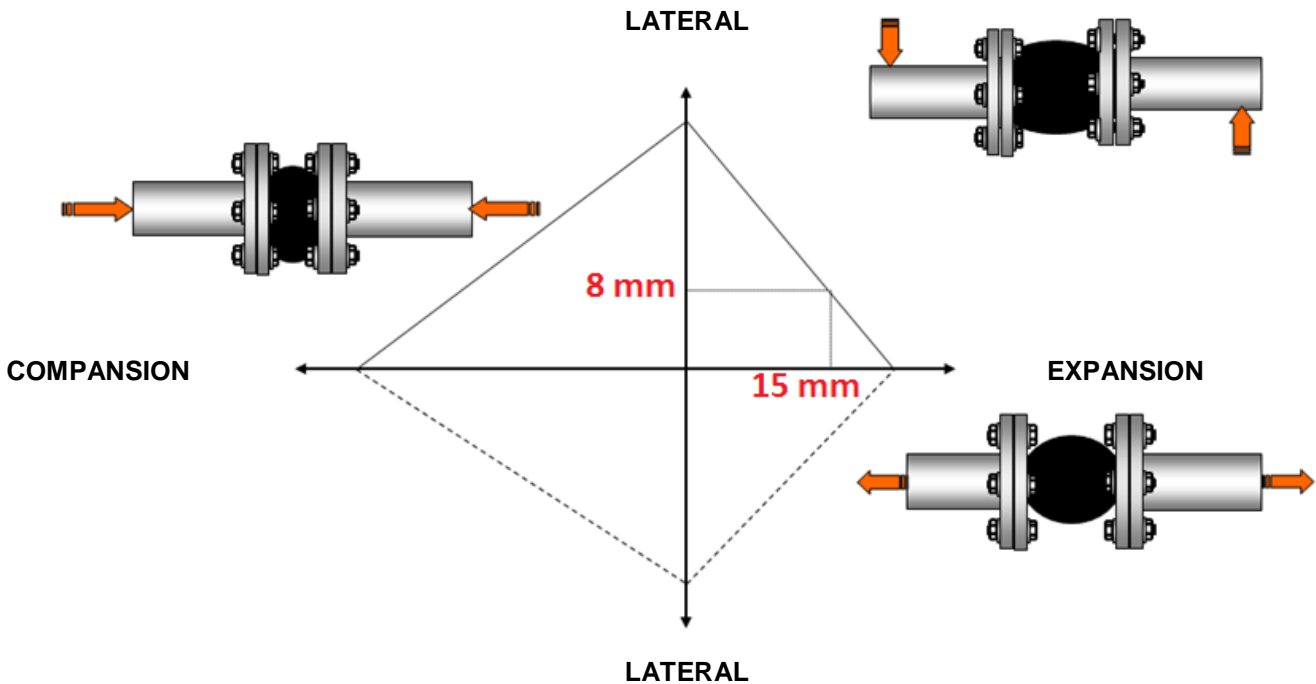

RUBBER EXPANSION JOINT TEGUFLEX® PU WHITE FOOD NBR

MARKING :



STANDARDS :

- Manufacturer certified ISO 9001 : 2015 and ISO 14001 : 2015
- DIRECTIVE 2014/68/EU : CE N° 0056
Risk category III Module H
- Flanges according to EN 1092-1 PN10/16
- Inner tube complies with U.S. **FDA CFR-21**
- Inner tube complies with European directive **1935/2004**

ADVICE : Our opinion and our advice are not guaranteed and SFERACO shall not be liable for the consequences of damages.
The customer must check the right choice of the products with the real service conditions.