

DUCTILE IRON FLANGED BALL CHECK VALVE PN10

Ductile iron flanged PN10 ball check valve for water distribution and watering.
Ductile iron body EN GJS-400-15 epoxy anticorrosion painting coated and stainless steel bolting.
Removable bonnet for easy maintenance.

Certificate

3.1



Size : DN40 to DN300
Connection : Flanges PN10/16 RF
Min Temperature : -10°C
Max Temperature : +90°C
Max Pressure : 10 Bars
Specifications : Ball type
Vertical or horizontal installation
Removable bonnet

Materials : Ductile iron body EN GJS-400-15

DUCTILE IRON FLANGED BALL CHECK VALVE PN10

SPECIFICATIONS :

- Ball type
- Vertical with ascendant fluid or horizontal (respect the flow direction indicated by the arrow)
- PN10/16 RF Flanges from DN40 to 150, PN10 over
- Easy maintenance thanks to the bolted bonnet
- Anti-corrosion epoxy painting RAL 5005 blue color, 250 microns thickness
- Anti-corrosion stainless steel bolting

USE :

- Water distribution and watering
- Min Temperature Ts : - 10°C
- Max Temperature Ts : + 90°C
- Max Pressure Ps : 10 bars

HEAD LOSS GRAPH :

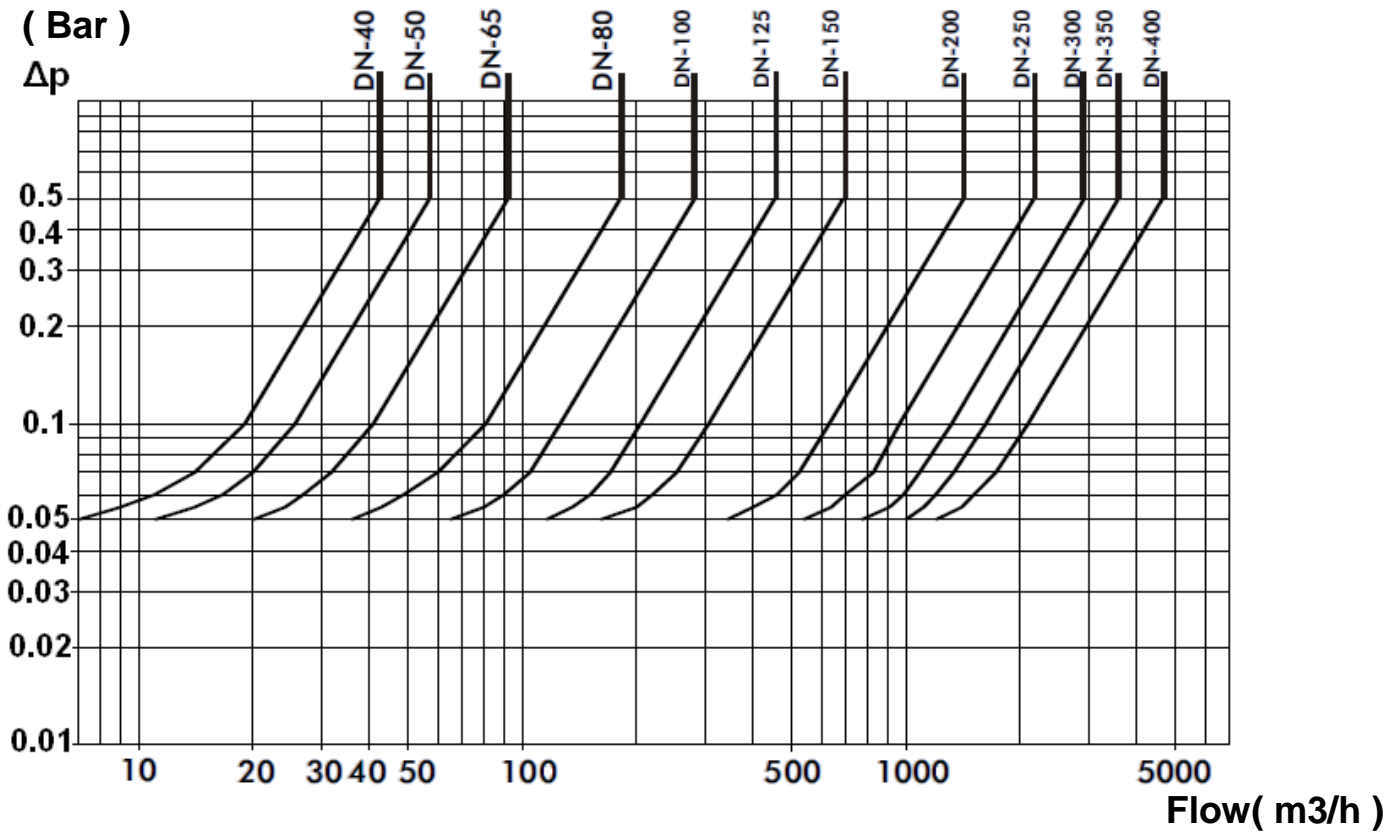

FLOW COEFFICIENT Kvs (in m3/h) :

DN	40	50	65	80	100	125	150	200	250	300
Kvs (m3/h)	60	81	130	255	400	645	970	2000	3050	4150

DUCTILE IRON FLANGED BALL CHECK VALVE PN10

RANGE :

- PN10/16 RF Flanges from DN40 to 150 and PN10 over **Ref. 332** from DN40 to 300

MATERIALS :

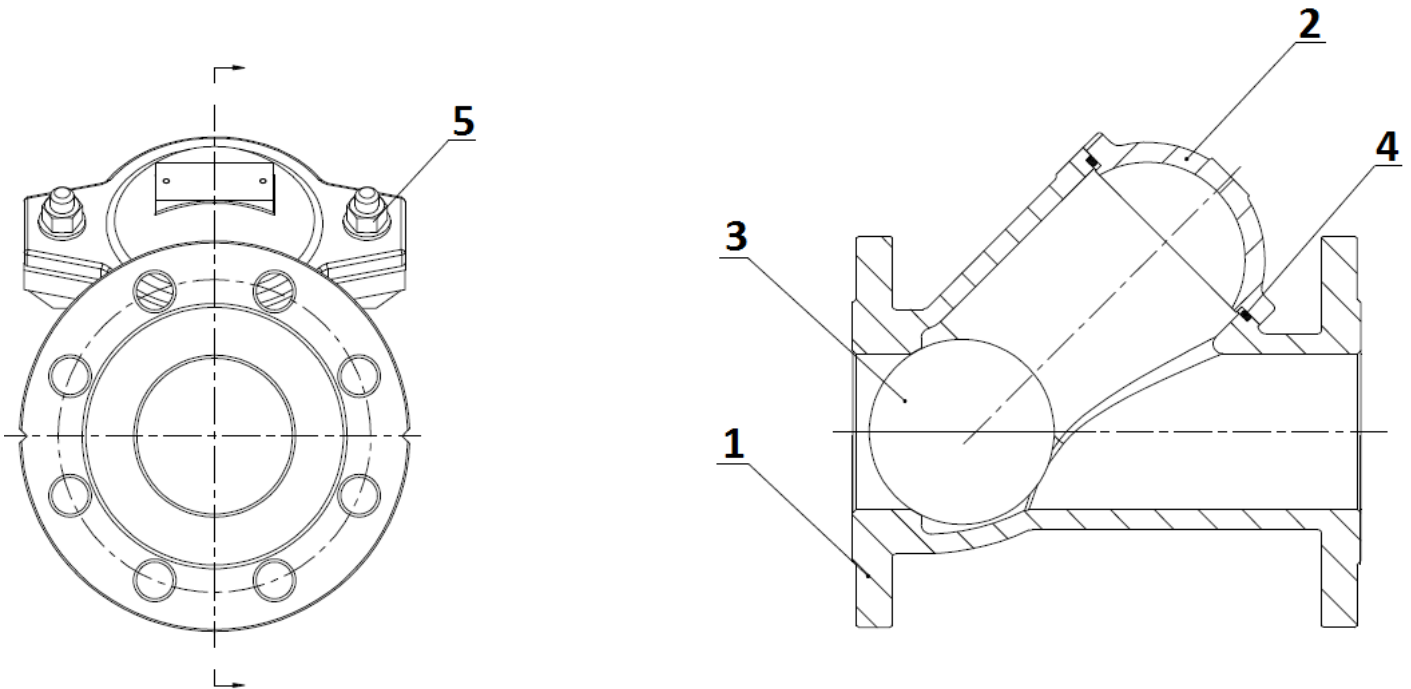

Item	Designation	Materials
1	Body	Ductile iron EN – GJS – 400-15
2	Bonnet	Ductile iron EN – GJS – 400-15
3	Ball DN 40	NBR
3	Ball DN 50 – DN80	Aluminium coated NBR
3	Ball DN 100 – 300	Carbon steel A216WCB coated NBR
4	Bonnet gasket	NBR
5	Bolting	AISI 304

DUCTILE IRON FLANGED BALL CHECK VALVE PN10

SIZE (in mm) :

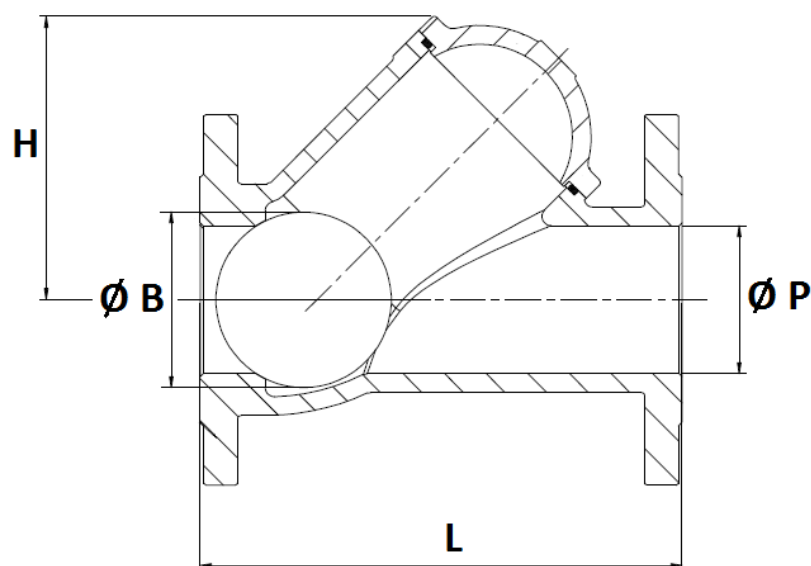
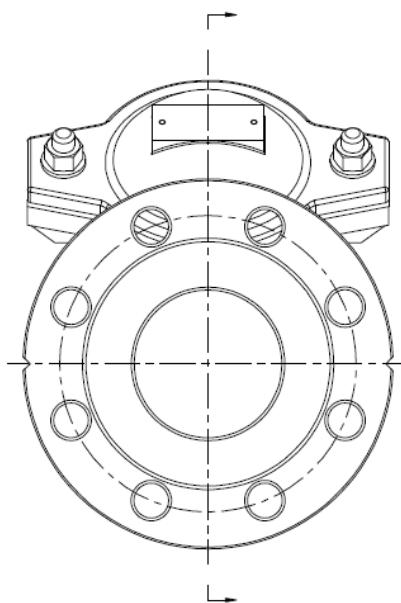

DN	40	50	65	80	100	125	150	200	250	300
L	180	200	240	260	300	350	400	500	600	700
H	103	111	141.5	151	190	239	280	338.5	413	472
Ø B	50	60	95	95	120	175	175	240	300	360
Ø P	40	51	80	80	100	144	150	200	250	300
Weight (in Kg)	6.09	9.32	16.1	17.8	17.5	38	38	103.6	135	191.8
Ref.	332040	332050	332065	332080	332100	332125	332150	332200	332250	332300

DUCTILE IRON FLANGED BALL CHECK VALVE PN10

FLANGES SIZE (in mm) :

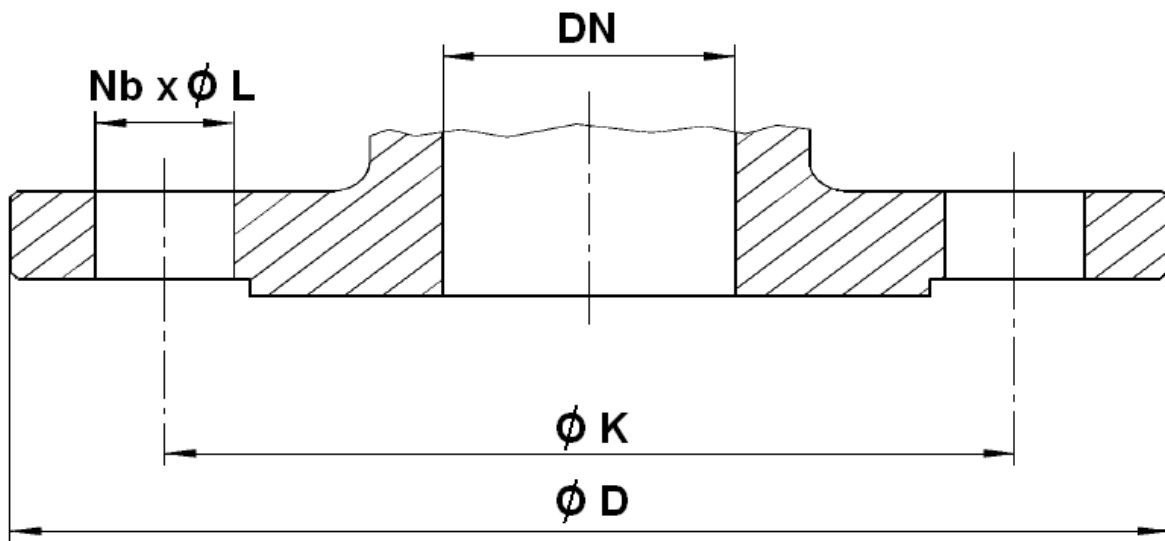

DN	40	50	65	80	100	125	150	200	250	300
Ø D	150	165	185	200	226	253	285	342	403	450
Ø K	110	125	145	160	180	210	240	295	350	400
Nb x Ø L	4 x 19	4 x 19	4 x 19	8 x 19	8 x 19	8 x 19	8 x 23	8 x 23	12 x 23	12 x 23

DUCTILE IRON FLANGED BALL CHECK VALVE PN10

STANDARDS :

- Manufacturer certified ISO 9001 : 2015
- DIRECTIVE 2014/68/EU : Products excluded from directive (Article 1, § 2b)
- Certificate 3.1 on request
- PN10 Flanges according to EN 1092-2
- Length according to EN 558 series 48 (DIN 3202 F6)
- **Body** test according to ISO 5208, Rate A

INSTALLATION POSITIONS :

Vertical position (Ascendant fluid)

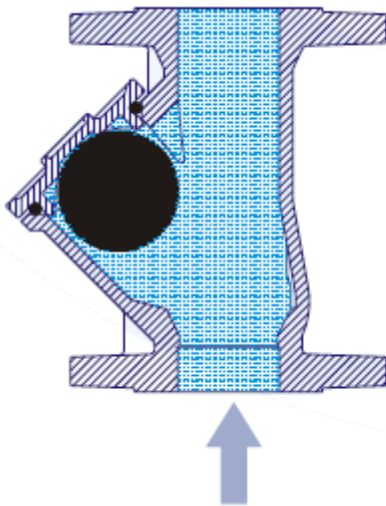

Horizontal position

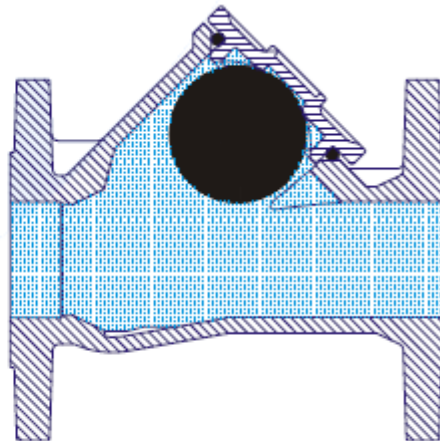

ADVICE : Our opinion and our advice are not guaranteed and SFERACO shall not be liable for the consequences of damages. The customer must check the right choice of the products with the real service conditions.